

化学成份与机械性能 CHEMICAL & MECHANICAL PROPERTIES

性能 property		材料 material	SRIM 050	052	SRIM 056	SRIM 058
JIS		HBSC4	HBSC4	FC250	S45C	
ASTM 或AISI		ASTM C86300	ASTM C86300	ASTM CLASS40	AISI 1045	
DIN		CuZn25A15	CuZn25A15	GG25	Ck45	
化学成分 Chemical Components (%)	Cu	60~68	60~68	——	——	
	Al	3~9	3~9	——	——	
	Mn	2.5~5	2.5~5	0.8~1.2	0.5~0.8	
	Fe	1.5~4.0	1.5~4.0	余量 Remains	余量 Remains	
	Zn	余量 Remains	余量 Remains	——	——	
	C	——	——	2.9~3.3	0.42~0.50	
	Si	——	——	1.4~1.8	0.17~0.37	
	其他 Other	——	——	——	——	
密度 (g/cm ³) Density		8.2	7.6	7.3	7.85	
硬度 (布氏) Hardness		HB>210	HB>260	HB>180	HRC>45	
抗拉强度 (N/mm ²) Tensile strength		>755	>850	>250	>700	
延伸率 (%) Elongation		>12	>2	——	>17	
承载力 Max. load	N/mm ²	100	120	70	30	
适用范围 Application		冶金机械, 矿山机械, 注塑机, 船舶工业, 航天航海, 水轮机, 气轮机, 灌装设备, 仪器仪表, 纺织机械, 模具行业等。 The product are widely applied in metallurgy and steel-rolling equipment, mine machinery, plastic mold machine industry, space voyage hydraulic turbine, gas turbine, filling equipment, instruments & apparatus, weave machinery and die industry etc.				
使用温度 Max. or Min. temperature		-40~+300	-40~+150	-40~+400	-40~+400	

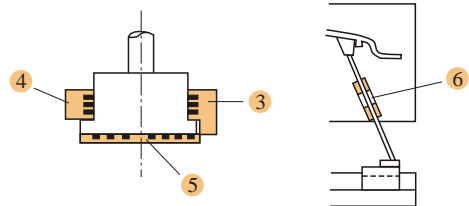

标号 NO.	型号规格 CODE NO.	标号 NO.	型号规格 CODE NO.
1	SRIM 050BF	5	SRIM 050PC
	SRIM 050FD		SRIM 052PA
2	SRIM 050BC		SRIM 058PA
	SRIM 050BI		SRIM 050PB
	SRIM 050BA		SRIM 050PG
3	SRIM 050PW		SRIM 050PA
	SRIM 050PX	6	SRIM 050BA
4	SRIM 050PY		

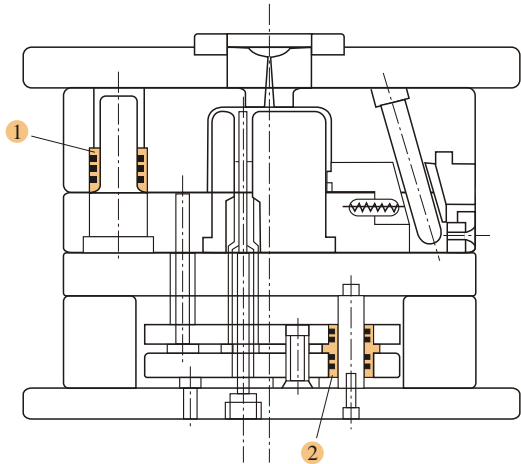
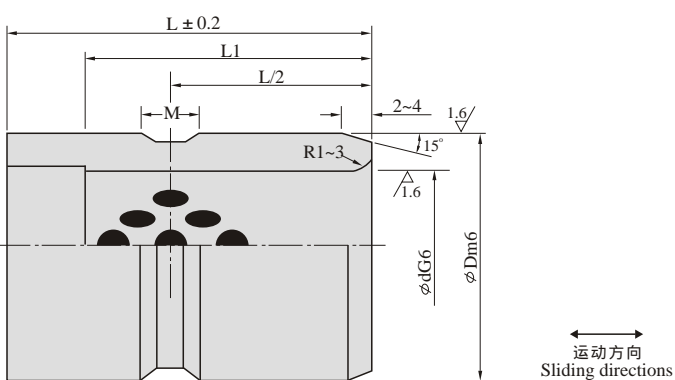

型号规格 Specification	ϕd	G6	ϕD	m6	L	L ₁	M
SRIM 050BF1209					9	9	—
SRIM 050BF1214	12		18	+0.018 +0.007	14	14	
SRIM 050BF1219					19	19	
SRIM 050BF1224					24	24	4
SRIM 050BF1314	13		20		14	14	
SRIM 050BF1319					19	19	
SRIM 050BF1324					24	24	
SRIM 050BF1329					29	29	6
SRIM 050BF1334		+0.017 +0.006			34	30	
SRIM 050BF1614	16		25		14	14	4
SRIM 050BF1619					19	19	
SRIM 050BF1624					24	24	
SRIM 050BF1629					29	29	
SRIM 050BF1634				+0.021 +0.008	34	34	6
SRIM 050BF1639					39	35	
SRIM 050BF2014	20		30		14	14	4
SRIM 050BF2019					19	19	
SRIM 050BF2024					24	24	
SRIM 050BF2029					29	29	
SRIM 050BF2034					34	34	6
SRIM 050BF2039					39	39	
SRIM 050BF2049					49	40	
SRIM 050BF2524	25		35		24	24	
SRIM 050BF2529					29	29	
SRIM 050BF2534					34	34	8
SRIM 050BF2539					39	39	
SRIM 050BF2549				+0.025 +0.009	49	49	
SRIM 050BF2559					59	50	
SRIM 050BF3029	30		42		29	29	
SRIM 050BF3034					34	34	8
SRIM 050BF3039					39	39	
SRIM 050BF3049					49	49	

型号规格 Specification	ϕd	G6	ϕD	m6	L	L1	M
SRIM 050BF3059					59	59	
SRIM 050BF3069	30	+0.020 +0.007	42		69	60	8
SRIM 050BF3079					79		
SRIM 050BF3529					29	29	
SRIM 050BF3534				+0.025 +0.009	34	34	
SRIM 050BF3539					39	39	
SRIM 050BF3549	35		48		49	49	8
SRIM B050BF3559					59	59	
SRIM 050BF3569					69	69	
SRIM 050BF3579					79	70	
SRIM 050BF4039					39	39	
SRIM 050BF4049		+0.025 +0.009			49	49	
SRIM 050BF4059	40		55		59	59	10
SRIM 050BF4069					69	69	
SRIM 050BF4079					79	79	
SRIM 050BF4089					89	80	
SRIM 050BF5049					49	49	
SRIM 050BF5059					59	59	
SRIM 050BF5069	50		70	+0.030 +0.011	69	69	10
SRIM 050BF5079					79	79	
SRIM 050BF5089					89	80	
SRIM 050BF5099					99	90	
SRIM 050BF6059					59	59	
SRIM 050BF6069					69	69	10
SRIM 050BF6079	60		80		79	79	
SRIM 050BF6089					89	89	
SRIM 050BF6099					99	90	
SRIM 050BF60109					109		
SRIM 050BF7069					69	69	
SRIM 050BF7079					79	79	
SRIM 050BF7089	70	+0.029 +0.010	90		89	89	10
SRIM 050BF7099					99	99	
SRIM 050BF70109					109	100	
SRIM 050BF70119				+0.035 +0.013	119		
SRIM 050BF8069					69	69	
SRIM 050BF8079					79	79	
SRIM 050BF8089	80		100		89	89	10
SRIM 050BF8099					99	99	
SRIM 050BF80109					109	100	
SRIM 050BF80119					119		

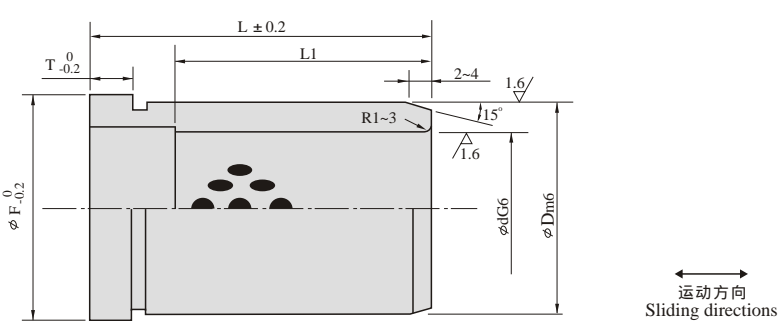

型号规格 Specification	ϕd	G6	ϕD	m6	ϕF	T	L	L_1
COB050FD1219							19	19
COB050FD1224							24	24
COB050FD1229	12		18	+0.018 +0.007		4	29	29
COB050FD1234							34	34
COB050FD1319					25		19	19
SRIM050FD1324							24	24
SRIM050FD1329	13		20			5	29	
SRIM050FD1334		+0.017 +0.006					34	25
SRIM050FD1339							39	
SRIM050FD1619							19	19
SRIM050FD1624							24	24
SRIM050FD1629							29	29
SRIM050FD1634	16		25		30	6	34	
SRIM050FD1639				+0.021 +0.008			39	30
SRIM050FD1649							49	
SRIM050FD2019							19	19
SRIM050FD2024							24	24
SRIM050FD2029							29	29
SRIM050FD2034	20		30		35	8	34	34
SRIM050FD2039							39	39
SRIM050FD2049							49	
SRIM050FD2059							59	40
SRIM050FD2524							24	24
SRIM050FD2529		+0.020 +0.007					29	29
SRIM050FD2534							34	34
SRIM050FD2539	25		35		40	8	39	39
SRIM050FD2549				+0.025 +0.009			49	49
SRIM050FD2559							59	59
SRIM050FD2569							69	69
SRIM050FD3029							29	29
SRIM050FD3034	30		42		47	10	34	34

型号规格 Specification	ϕd	G6	ϕD	m6	ϕF	T	L	L ₁
SRIM050FD3039							39	39
SRIM050FD3049							49	49
SRIM050FD3059	30	+0.020 +0.007	42		47	10	59	59
SRIM050FD3069							69	60
SRIM050FD3079							79	
SRIM050FD3539							39	39
SRIM050FD3549				+0.025 +0.009			49	49
SRIM050FD3559							59	59
SRIM050FD3569	35		48		54	10	69	69
SRIM050FD3579							79	
SRIM050FD3589							89	70
SRIM050FD3599							99	
SRIM050FD4039							39	39
SRIM050FD4049							49	49
SRIM050FD4059		+0.025 +0.009					59	59
SRIM050FD4069	40		55		61	10	69	69
SRIM050FD4079				79			79	
SRIM050FD4089				89				
SRIM050FD4099							99	80
SRIM050FD40109							109	
SRIM050FD5049				+0.030 +0.011			49	49
SRIM050FD5059							59	59
SRIM050FD5069							69	69
SRIM050FD5079	50		70		76	12	79	79
SRIM050FD5089				89			89	
SRIM050FD5099				99				
SRIM050FD50109							109	90
SRIM050FD50119							119	
SRIM050FD6099							99	99
SRIM050FD60109							109	109
SRIM050FD60119	60		80		86	15	119	
SRIM050FD60129				129			110	
SRIM050FD60149				149				
SRIM050FD7099							99	99
SRIM050FD70109							109	109
SRIM050FD70119	70	+0.029 +0.010	90		96	15	119	119
SRIM050FD70129				129			120	
SRIM050FD70149				149				
SRIM050FD8099				+0.035 +0.013			99	99
SRIM050FD80109							109	109
SRIM050FD80119	80		100		108	15	119	119
SRIM050FD80129				129			120	
SRIM050FD80149				149				

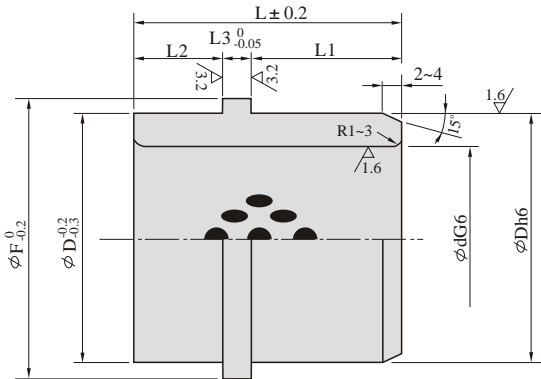

型号规格 Specification	ϕd	G6	ϕD	h6	ϕF	L	L ₁	L ₂	L ₃
SRIM050BC1024	10	+0.014 +0.005	16	0 -0.011	21	24	10		
SRIM050BC1028						28	14		
SRIM050BC1226	12		18			26	12		
SRIM050BC1228						28	14		
SRIM050BC1326	13	+0.017 +0.006	22		25	26	12		
SRIM050BC1328						28	14		
SRIM050BC1333						33	19		
SRIM050BC1338						38	24		
SRIM050BC1626	16		25	0 -0.013	30	26	12		
SRIM050BC1628						28	14	10	
SRIM050BC1633						33	19		
SRIM050BC1638						38	24		
SRIM050BC2026	20		30		35	26	12		
SRIM050BC2028						28	14		
SRIM050BC2033						33	19		
SRIM050BC2038						38	24		
SRIM050BC2526	25	+0.020 +0.007	35		40	26	12		4
SRIM050BC2528						28	14		
SRIM050BC2533						33	19		
SRIM050BC2538						38	24		
SRIM050BC3033	30		40	0 -0.016	45	33	14		
SRIM050BC3038						38	19	15	
SRIM050BC3043						43	24		
SRIM050BC3238						38	19		
SRIM050BC3243	32		42		47	43	24		
SRIM050BC3248						48	29		
SRIM050BC3538	35	+0.025 +0.009	46		50	38	19		
SRIM050BC3543						43	24		
SRIM050BC3548						48	29		
SRIM050BC4048						48	24		
SRIM050BC4053	40		52	0 -0.019	57	53	29		
SRIM050BC5048						48	24	20	
SRIM050BC5053						53	29		

运动方向
Sliding directions

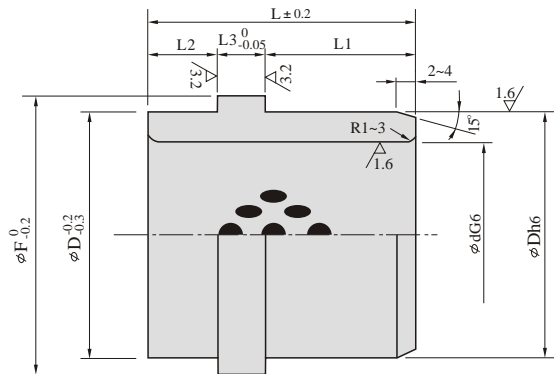

型号规格 Specification	ϕd	G6	ϕD	h6	ϕF	L	L ₁	L ₂	L ₃	
SRIM 050BI3037	30		42	$\begin{smallmatrix} 0 \\ -0.016 \end{smallmatrix}$	47	37	14	15		
SRIM 050BI3042						42	19			
SRIM 050BI3047						47	24			
SRIM 050BI3052						52	29			
SRIM 050BI4053	40		55	$\begin{smallmatrix} 0 \\ -0.019 \end{smallmatrix}$	60	53	20	25		
SRIM 050BI4057						57	24			
SRIM 050BI4060						60	32			20
SRIM 050BI4067	50	$\begin{smallmatrix} +0.025 \\ +0.009 \end{smallmatrix}$	55	$\begin{smallmatrix} 0 \\ -0.019 \end{smallmatrix}$	60	67	29	30		
SRIM 050BI4070						70	42			20
SRIM 050BI5067						67	29			30
SRIM 050BI5087	60		62	$\begin{smallmatrix} 0 \\ -0.019 \end{smallmatrix}$	67	87	39	40		
SRIM 050BI6067						67	29			30
SRIM 050BI6087						87	39			40

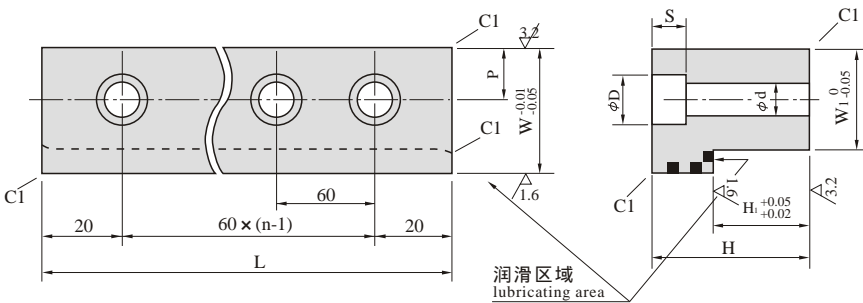

型号规格 Specification	L	H	E	F	G	a	P1	n	b	P2
SRIM050PW10030			100			2				
SRIM050PW16030			160	30	15	3				
SRIM050PW22030	23	15	220			4	7.5	11	7	7
SRIM050PW10041			100			2				
SRIM050PW16041			160	41	26	3				
SRIM050PW22041			220			4				
SRIM050PW10025			100			2				
SRIM050PW16025			160	25	10	3				
SRIM050PW22025			220			4	10	18	11	13
SRIM050PW10035	28	20	100			2				
SRIM050PW16035			160	35	15	3				
SRIM050PW22035			220			4				
SRIM050PW10056			100			2				
SRIM050PW16056			160	56	26	3	10	14	9	10
SRIM050PW22056			220			4				

运动方向
Sliding directions

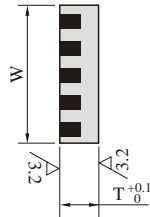
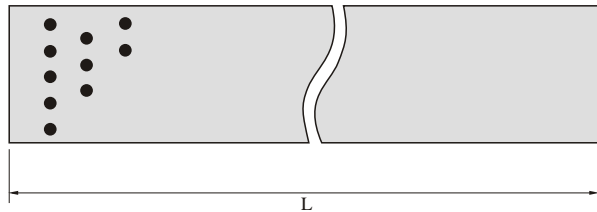

型号规格 Specification	W	H	L
SRIM 050PC2005305	20		
SRIM 050PC2505305	25		305
SRIM 050PC3005305		5.3	
SRIM 050PC3005400	30		400
SRIM 050PC3510605	35		
SRIM 050PC4010605	40	10.3	
SRIM 050PC5010605	50		
SRIM 050PC6015605	60		605
SRIM 050PC8015605		15.3	
SRIM 050PC8020605	80		
SRIM 050PC10020605	100	20.3	

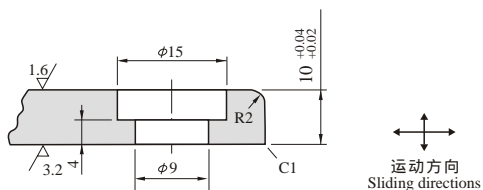
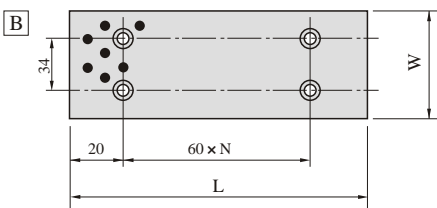
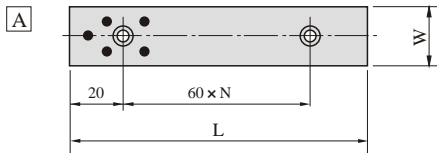

型号规格 Specification	W	L	N	螺钉数 holes	尺寸图 Sketch
SRIM 052PA18100		100	1	2	
SRIM 052PA18160	18	160	2	3	
SRIM 052PA18220		220	3	4	
SRIM 052PA28100		100	1	2	
SRIM 052PA28160	28	160	2	3	
SRIM 052PA28220		220	3	4	A
SRIM 052PA38100		100	1	2	
SRIM 052PA38160	38	160	2	3	
SRIM 052PA38220		220	3	4	
SRIM 052PA48100		100	1	2	
SRIM 052PA48160	48	160	2	3	
SRIM 052PA48220		220	3	4	
SRIM 052PA58100		100	1	4	
SRIM 052PA58160	58	160	2	6	
SRIM 052PA58220		220	3	8	
SRIM 052PA68100		100	1	4	B
SRIM 052PA68160	68	160	2	6	
SRIM 052PA68220		220	3	8	

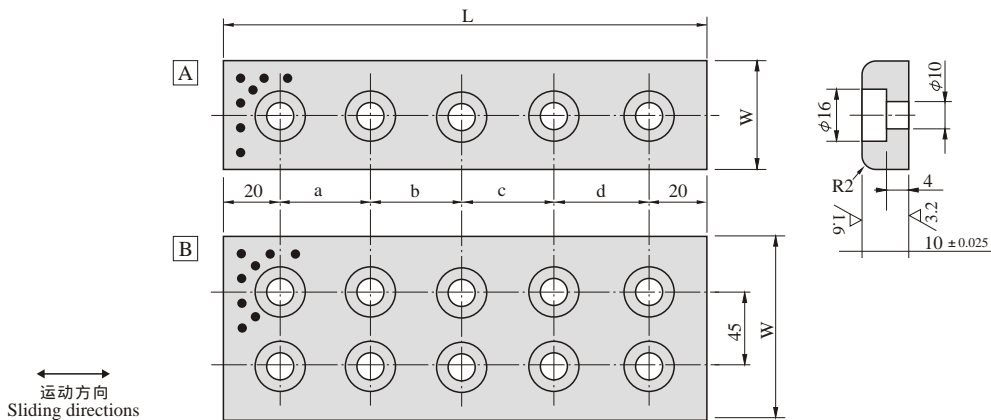

型号规格 Specification	W	L	a	b	c	d	螺钉 bolt	螺钉数 holes	尺寸图 Sketch
SRIM 050PB35100	35	100	60	—	—	—	M8	2	A
SRIM 050PB35150		150	55	55	—	—		3	
SRIM 050PB35200		200	55	50	55	—		4	
SRIM 050PB35250		250	70	70	70	—		4	
SRIM 050PB35300		300	65	65	65	65		5	
SRIM 050PB35350		350	80	75	75	80		5	
SRIM 050PB50100	50	100	60	—	—	—	M8	2	A
SRIM 050PB50150		150	55	55	—	—		3	
SRIM 050PB50200		200	55	50	55	—		4	
SRIM 050PB50250		250	70	70	70	—		4	
SRIM 050PB50300		300	65	65	65	65		5	
SRIM 050PB50350		350	80	75	75	80		5	
SRIM 050PB75150	75	150	110	—	—	—	M8	4	B
SRIM 050PB75200		200	80	80	—	—		6	
SRIM 050PB75250		250	105	105	—	—		6	
SRIM 050PB75300		300	85	90	85	—		8	
SRIM 050PB75400		400	120	120	120	—		8	
SRIM 050PB75500		500	115	115	115	115		10	

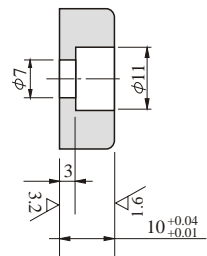
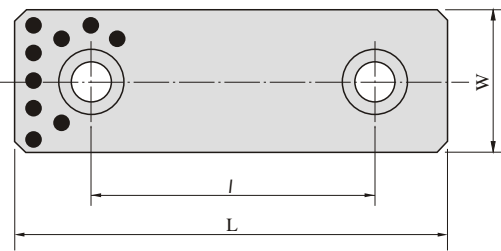

型号规格 Specification	W	L	l
SRIM 050PA1875	18	75	45
SRIM 050PA18100		100	50
SRIM 050PA18125		125	75
SRIM 050PA18150	28	150	100
SRIM 050PA2875		75	45
SRIM 050PA28100		100	50
SRIM 050PA28125	38	125	75
SRIM 050PA28150		150	100
SRIM 050PA3875		75	45
SRIM 050PA38100	48	100	50
SRIM 050PA38125		125	75
SRIM 050PA38150		150	100
SRIM 050PA4875	48	75	45
SRIM 050PA48100		100	50
SRIM 050PA48125		125	75
SRIM 050PA48150		150	100

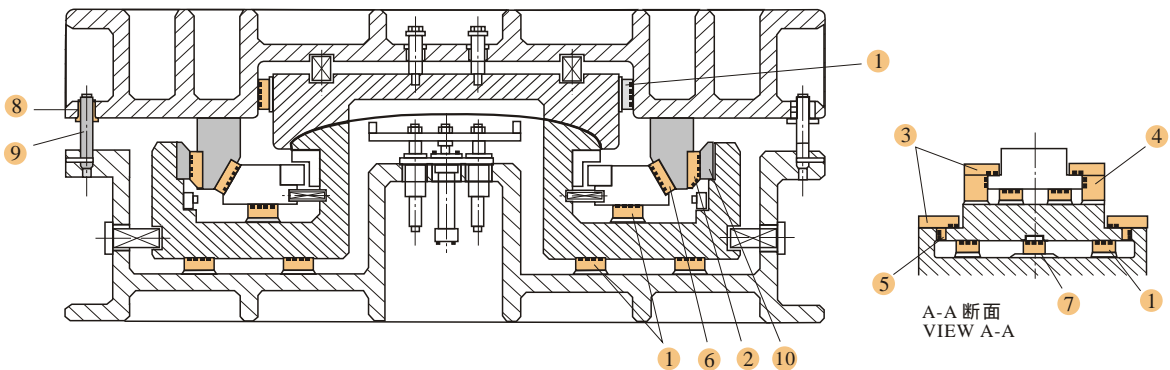

标号 NO.	型号规格 CODE NO.	标号 NO.	型号规格 CODE NO.	标号 NO.	型号规格 CODE NO.
①	SRIM 050PD	③	SRIM 050PI	⑦	SRIM 056PG
	SRIM 056PA		SRIM 058PE		SRIM 056BA
	SRIM 056PB		SRIM 058PF		SRIM 050FC
	SRIM 050PG		SRIM 056PC		SRIM 050BE
	SRIM 050PH		SRIM 056PE	⑧	SRIM 056BB
	SRIM 058PA		SRIM 056PB		SRIM 050FC
②	SRIM 050PM	⑤	SRIM 050PG	⑨	SRIM 058BA
	SRIM 050PN		SRIM 050PK		SRIM 058PG
③	SRIM 056PB	⑥	SRIM 050PU	⑩	SRIM 058PH
	SRIM 050PJ		SRIM 050BD		

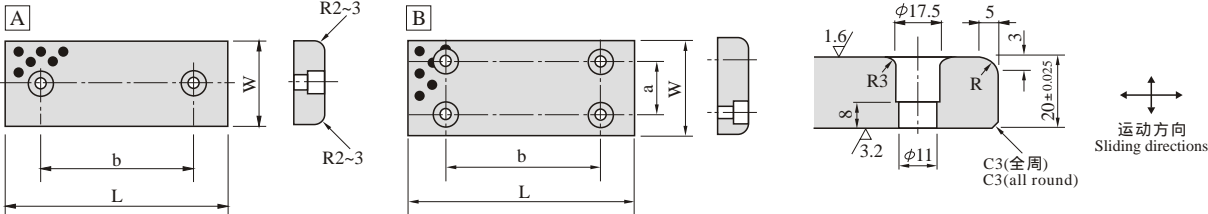

型号规格 Specification	W	L	a	b	尺寸图 Sketch
SRIM 050PD2875		75		45	
SRIM 050PD28100	28	100	—	50	
SRIM 050PD28150		150		100	
SRIM 050PD3875		75		45	
SRIM 050PD38100	38	100	—	50	
SRIM 050PD38150		150		100	
SRIM 050PD4875		75		45	
SRIM 050PD48100		100		50	
SRIM 050PD48125	48	125	—	75	
SRIM 050PD48150		150		100	A
SRIM 050PD48200		200		150	
SRIM 050PD5875		75		45	
SRIM 050PD58100	58	100	—	50	
SRIM 050PD58150		150		100	
SRIM 050PD7575		75		25	
SRIM 050PD75100		100		50	
SRIM 050PD75125	75	125	—	75	
SRIM 050PD75150		150		100	
SRIM 050PD75200		200		150	
SRIM 050PD100100		100		50	
SRIM 050PD100125		125		75	
SRIM 050PD100150	100	150	50	100	
SRIM 050PD100200		200		150	
SRIM 050PD100250		250		200	
SRIM 050PD100300		300		200	
SRIM 050PD125125		125		75	
SRIM 050PD125150		150		100	B
SRIM 050PD125200	125	200	50	150	
SRIM 050PD125250		250		200	
SRIM 050PD125300		300		200	
SRIM 050PD125350		350		200	
SRIM 050PD150150		150		100	
SRIM 050PD150200	150	200	100	150	
SRIM 050PD150250		250		200	

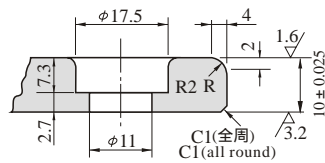
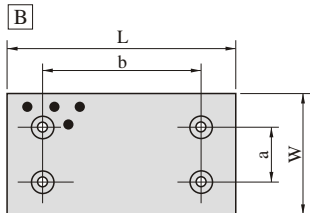
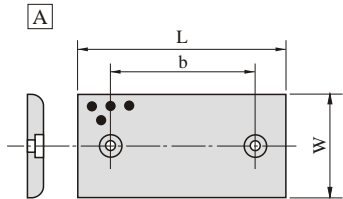

型号规格 Specification	W	L	a	b	尺寸图 Sketch		
SRIM 050PG2875	28	75	—	45	A		
SRIM 050PG28100		100		50			
SRIM 050PG28125		125		75			
SRIM 050PG28150		150		100			
SRIM 050PG3875		75		45			
SRIM 050PG38100	38	100	—	50	A		
SRIM 050PG38125		125		75			
SRIM 050PG38150		150		100			
SRIM 050PG4875	48	75	—	45	A		
SRIM 050PG48100		100		50			
SRIM 050PG48125		125		75			
SRIM 050PG48150		150		100			
SRIM 050PG48200		200		150			
SRIM 050PG7575	75	75	—	25	A		
SRIM 050PG75100		100		50			
SRIM 050PG75125		125		75			
SRIM 050PG75150		150		100			
SRIM 050PG75200		200		150			
SRIM 050PG100100	100	100	50	50	B		
SRIM 050PG100125		125		75			
SRIM 050PG100150		150		100			
SRIM 050PG100200		200		150			
SRIM 050PG100250		250		200			
SRIM 050PG125150	125	150	50	100	B		
SRIM 050PG125200		200		150			
SRIM 050PG125250		250		200			
SRIM 050PG150150		150		150		100	100
SRIM 050PG150200				200			150

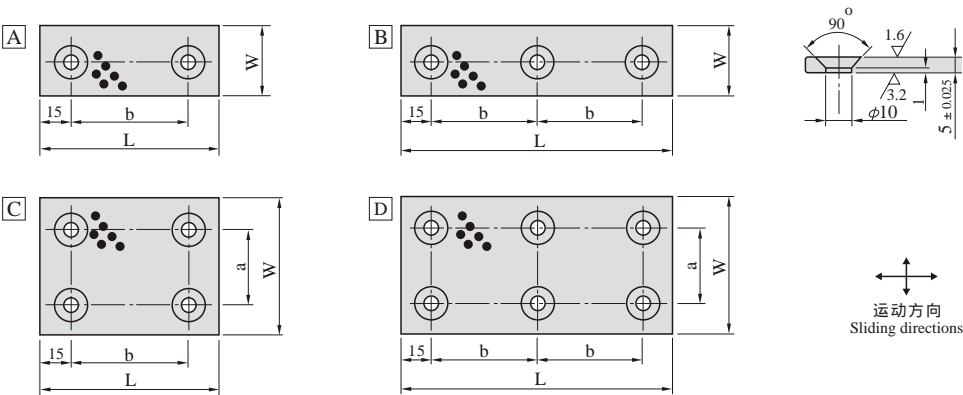

型号规格 Specification	W	L	a	b	尺寸图 Sketch
SRIM 050PH1850	18	50	—	20	A
SRIM 050PH1875		75		45	
SRIM 050PH18100		100		70	
SRIM 050PH18150	28	150	—	60	B
SRIM 050PH2850		50		20	
SRIM 050PH2875		75		45	
SRIM 050PH28100	38	100	—	70	A
SRIM 050PH28150		150		60	
SRIM 050PH3850		50		20	
SRIM 050PH3875	48	75	—	45	A
SRIM 050PH38100		100		70	
SRIM 050PH38150		150		60	
SRIM 050PH4875	75	75	45	45	C
SRIM 050PH48100		100		70	
SRIM 050PH48125		125		95	
SRIM 050PH48150	100	150	70	60	D
SRIM 050PH7575		75		45	
SRIM 050PH75100		100		70	
SRIM 050PH75125	150	125	70	95	C
SRIM 050PH75150		150		60	
SRIM 050PH100100		100		70	
SRIM 050PH100125	100	125	70	95	C
SRIM 050PH100150		150		60	

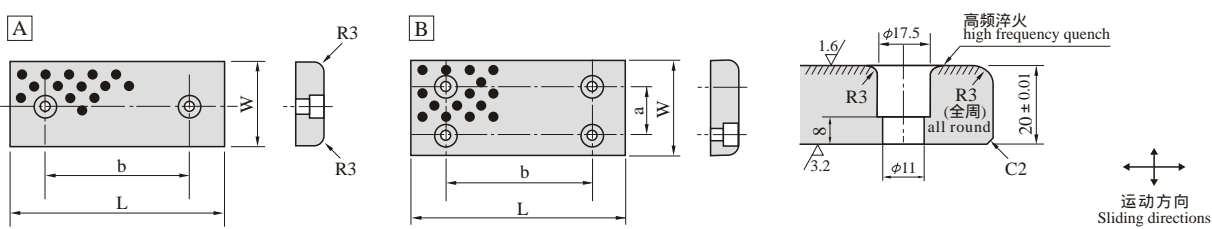

型号规格 Specification	W	L	a	b	尺寸图 Sketch
SRIM 058PA4875		75		45	
SRIM 058PA48100		100		50	
SRIM 058PA48125	48	125	—	75	
SRIM 058PA48150		150		100	
SRIM 058PA48200		200		150	
SRIM 058PA7575		75		25	A
SRIM 058PA75100		100		50	
SRIM 058PA75125	75	125	—	75	
SRIM 058PA75150		150		100	
SRIM 058PA75200		200		150	
SRIM 058PA100100		100		50	
SRIM 058PA100125		125		75	
SRIM 058PA100150	100	150	50	100	
SRIM 058PA100200		200		150	
SRIM 058PA100250		250		200	
SRIM 058PA125125		125		75	
SRIM 058PA125150		150		100	B
SRIM 058PA125200	125	200	50	150	
SRIM 058PA125250		250		200	
SRIM 058PA150150		150		100	
SRIM 058PA150200	150	200	100	150	
SRIM 058PA150250		250		200	

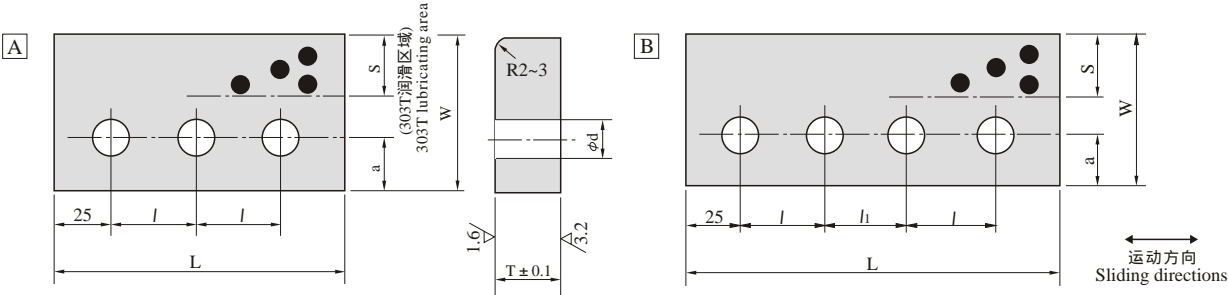

型号规格 Specification	T	L	W	l	l ₁	a	s	φd	尺寸图 Sketch
SRIM 056PD20150		150		50	—				A
SRIM 056PD20200	20	200	52	75	—	20	12	13	B
SRIM 056PD20250		250			50				A
SRIM 056PD30150		150		50	—				B
SRIM 056PD30200	30	200	72	75	—		22		A
SRIM 056PD30250		250			50				B
SRIM 056PD35150		150		50	—				A
SRIM 056PD35200	35	200	77	75	—		27		B
SRIM 056PD35250		250			50			18	A
SRIM 056PD40150		150		50	—	25			B
SRIM 056PD40200		200	82	75	—				A
SRIM 056PD40250	40	250			50		32		B
SRIM 056PD40150D		150		50	—				A
SRIM 056PD40200D		200	105						B
SRIM 056PD40250D		250		75	50				A

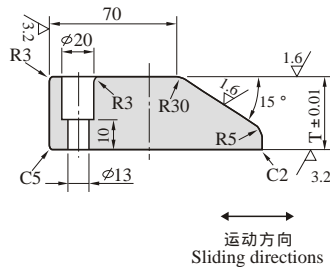
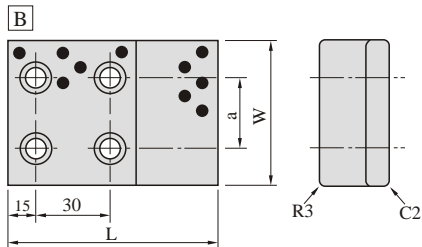
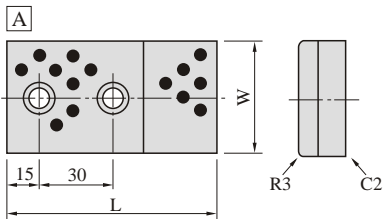

型号规格 Specification	W	L	T	a	尺寸图 Sketch
SRIM050PN50110		110	25		
SRIM050PN50130	50	130	30	—	A
SRIM050PN50150		150	35		
SRIM050PN75110		110	25		
SRIM050PN75130	75	130	30	40	
SRIM050PN75150		150	35		
SRIM050PN100110		110	25		B
SRIM050PN100130	100	130	30	60	
SRIM050PN100150		150	35		

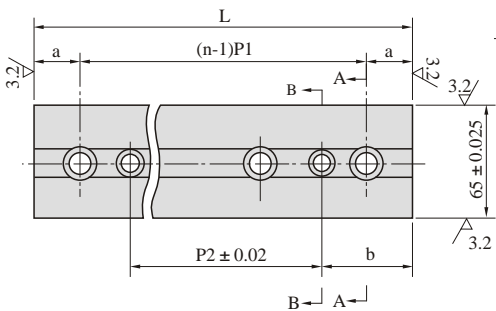

高频淬火 (斜线部)
high frequency quench
(oblique line area)

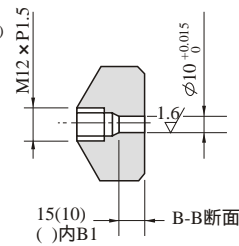
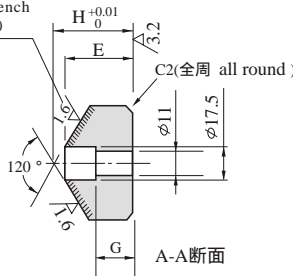

型号规格 Specification	L	H	E	G	a	P1	n	b	P2
SRIM 058PI100	100				20	60	2	40	20
SRIM 058PI150	150						3		50
SRIM 058PI200	200	47	44	20			4		100
SRIM 058PI250	250				25	50	5	50	150
SRIM 058PI300	300						6		200
SRIM 058PI100B	100				20	60		40	20
SRIM 058PI125B	125					75	2		25
SRIM 058PI150B	150					100			50
SRIM 058PI200B	200	30	26	10	25	75		50	100
SRIM 058PI250B	250					100	3		150
SRIM 058PI300B	300					125			200

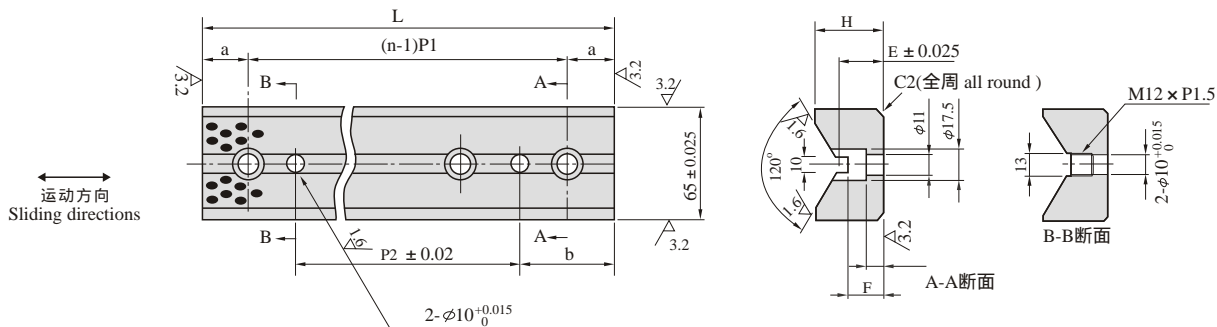

型号规格 Specification	L	H	E	F	G	a	P1	n	b	P2
SRIM 050PO100	100					20	60	2	40	20
SRIM 050PO150	150							3		50
SRIM 050PO200	200	35	18	15	8			4		100
SRIM 050PO250	250					25	50	5	50	150
SRIM 050PO300	300							6		200
SRIM 050PO100B	100					20	60		40	20
SRIM 050PO125B	125						75	2		25
SRIM 050PO150B	150						100			50
SRIM 050PO200B	200	37	20	20	10	25	75		50	100
SRIM 050PO250B	250						100	3		150
SRIM 050PO300B	300						125			200

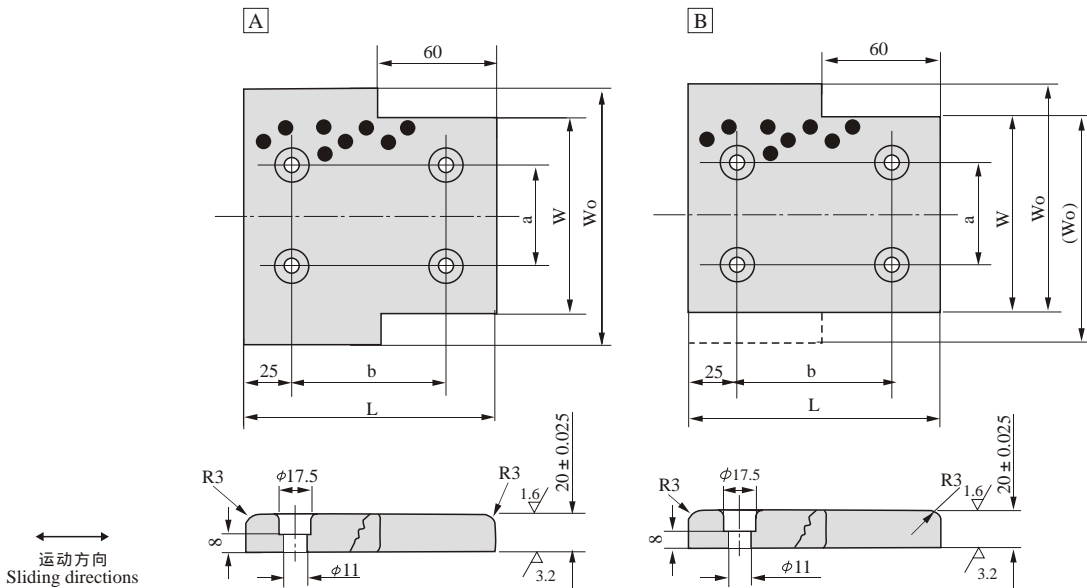

型号规格 Specification	W	L	W ₀	a	b	尺寸图 Sketch
SRIM 050PS100125	100	125	130	50	75	
SRIM 050PS100150		150			100	
SRIM 050PS125150	125	150	155	75	100	A
SRIM 050PS125200		200			150	
SRIM 050PS125250		250			200	
SRIM 050PS150200	150	200	180	100	150	
SRIM 050PS150250		250			200	
SRIM 050PS100125B	100	125	115	50	75	
SRIM 050PS100150B		150			100	
SRIM 050PS125150B	125	150	140	75	100	B
SRIM 050PS125200B		200			150	
SRIM 050PS125250B		250			200	
SRIM 050PS150200B	150	200	165	100	150	
SRIM 050PS150250B		250			200	

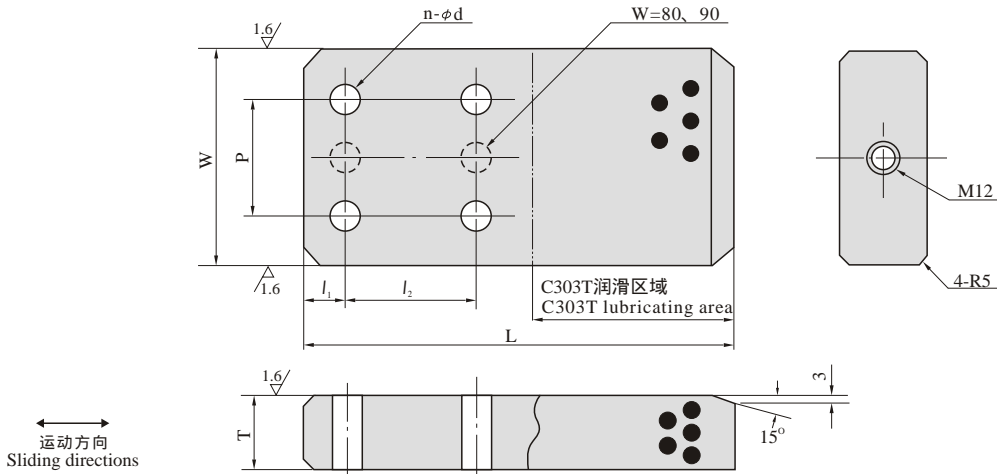

型号规格 Specification	W公差		L	T	S	l_1	l_2	P	n	ϕd
SRIM056PH80220			220				60			
SRIM056PH80260	80	$\begin{matrix} 0 \\ -0.025 \end{matrix}$	260	40	80		70	—	2	
SRIM056PH80300			300			25				22
SRIM056PH120280			280				80			
SRIM056PH120340	120	$\begin{matrix} 0 \\ -0.035 \end{matrix}$	340	60	120		100	70		
SRIM056PH120380			380							
SRIM056PH150340			340							
SRIM056PH150380	150	$\begin{matrix} 0 \\ -0.040 \end{matrix}$	380	75	130		110	100	4	
SRIM056PH150430			430			30				26
SRIM056PH180340			340							
SRIM056PH180380	180	$\begin{matrix} 0 \\ -0.046 \end{matrix}$	380	90	140		130	120		
SRIM056PH180430			430							
SRIM056PH90220			220				60			
SRIM056PH90260	90	$\begin{matrix} 0 \\ -0.025 \end{matrix}$	260	40	80		70	—	2	
SRIM056PH90300			300			25				22
SRIM056PH130280			280				80			
SRIM056PH130340	130	$\begin{matrix} 0 \\ -0.035 \end{matrix}$	340	60	120		100	70		
SRIM056PH130380			380							
SRIM056PH160340			340			30				26
SRIM056PH160380	160	$\begin{matrix} 0 \\ -0.040 \end{matrix}$	380	75	130		110	100	4	
SRIM056PH160430			430							
SRIM056PH190340			340							
SRIM056PH190380	190	$\begin{matrix} 0 \\ -0.046 \end{matrix}$	380	90	140		130	120		
SRIM056PH190430			430							

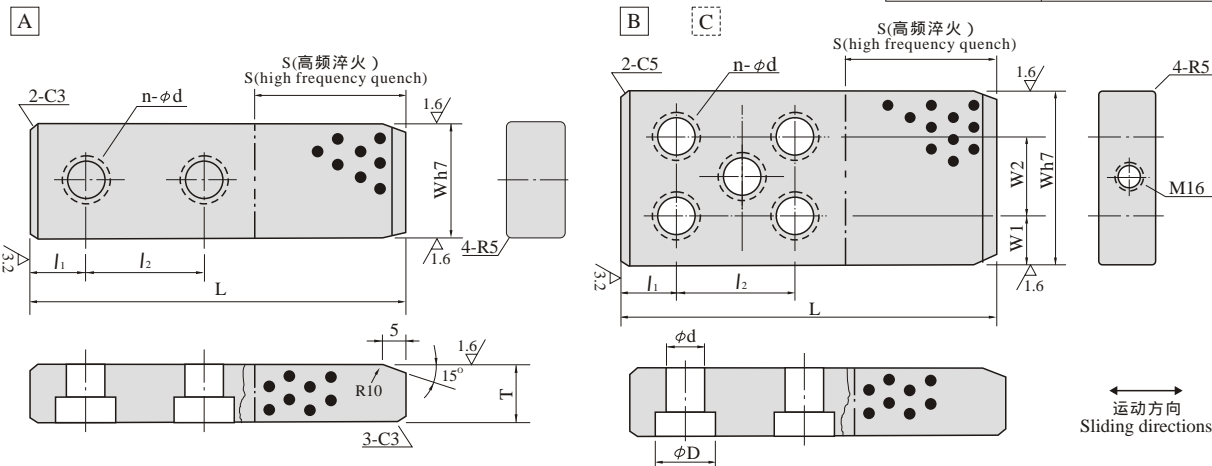

型号规格 Specification	Wh7	L	T	S	l_1	l_2	W1	W2	n	尺寸图 Sketch
SRIM058PN50160		160		60		50				
SRIM058PN50200	$50_{-0.025}^0$	200	30	120	20	80				
SRIM058PN50260		260					—	—	2	A
SRIM058PN70230		230		100		60				
SRIM058PN70260		260	35	160	25	75				
SRIM058PN70300	$70_{-0.030}^0$	300				150				
SRIM058PN70350		350		150		150				
SRIM058PN100230		230		100		60				
SRIM058PN100280		280					20			
SRIM058PN100330	$100_{-0.035}^0$	330		160		100				
SRIM058PN100390		390		200		120		60		
SRIM058PN120230		230	45	100		60				
SRIM058PN120280		280								
SRIM058PN120330	$120_{-0.035}^0$	330		160		100			4	B
SRIM058PN120390		390		200		120				
SRIM058PN150280		280		160		60				
SRIM058PN150330		330	50		30	80				
SRIM058PN150390	$150_{-0.040}^0$	390		190		140		90		
SRIM058PN150430		430				180	30			
SRIM058PN180280		280		160		60				
SRIM058PN180330		330	55			80				
SRIM058PN180390		390		190		140				
SRIM058PN180430	$180_{-0.040}^0$	430				180		120	5	C
SRIM058PN180480		480		200		200				
SRIM058PN180550		550		250		225				

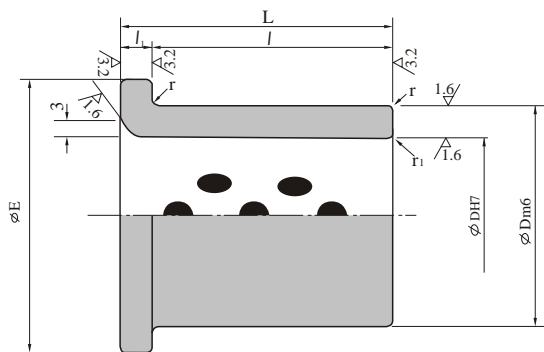
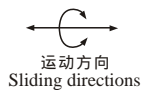

型号规格 Specification	ϕd	H7	L	ϕD	m6	ϕE	h_i	l	R	r	r1
SRIM 050FC2540	25	+0.021	40	35	+0.025	45	7	33	R10	R1	
SRIM 050FC3050	30	0	50	40	+0.009	50	40				
SRIM 050FC4070	40	+0.025	70	55		65	60				
SRIM 050FC5080	50	0		65		75					
SRIM 050FC6080	60		80	75	+0.030	85	70			R2	
SRIM 050FC6580					+0.011						
SRIM 050FC65120	65	+0.030	120	80		90	10	110	R20	R2	
SRIM 050FC80100		0	100								
SRIM 050FC80140	80		140	100	+0.035	110		130			
SRIM 050FC100100			100								
SRIM 050FC100140	100	+0.025	140	120	+0.013	130		90			
SRIM 050FC100140		0	140								